

Perkins Sabre M265Ti and M300Ti Marine Diesel Engine shown with the MPM 220A gearbox (Ratios up to and including 2:1) (622 mm transverse mounting centres)

SABRE ENGINES LTD
 Wimborne, Dorset, England.
 Tel. +44(0)1202 893720
 Fax. +44(0)1202 851700
 E-mail. Post@Sabre-engines.co.uk
 www.Perkins-Sabre.com

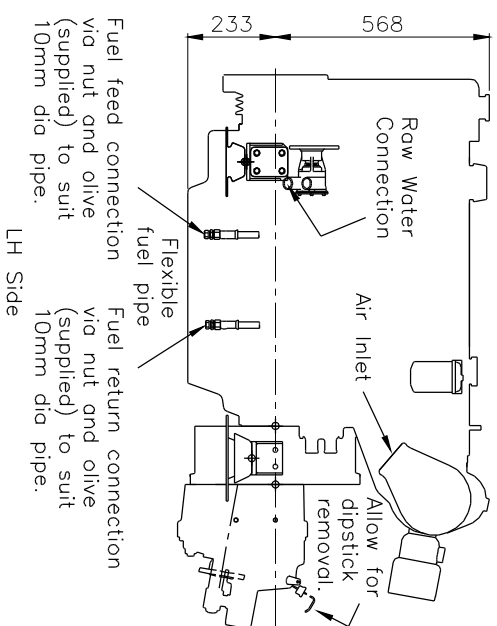
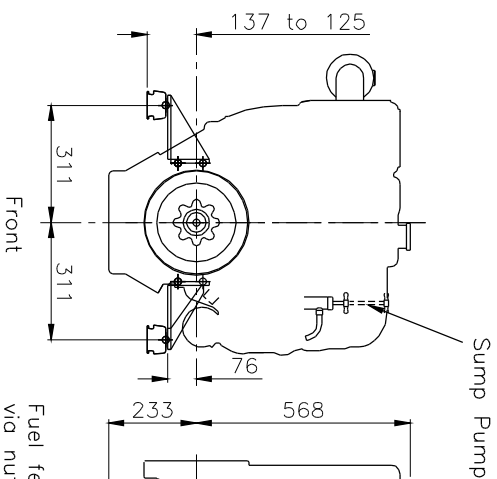
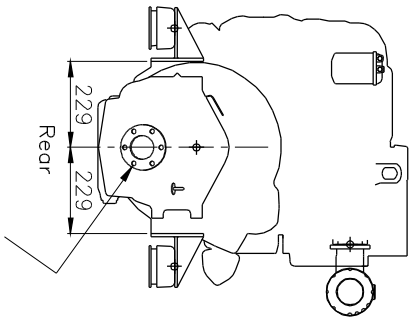
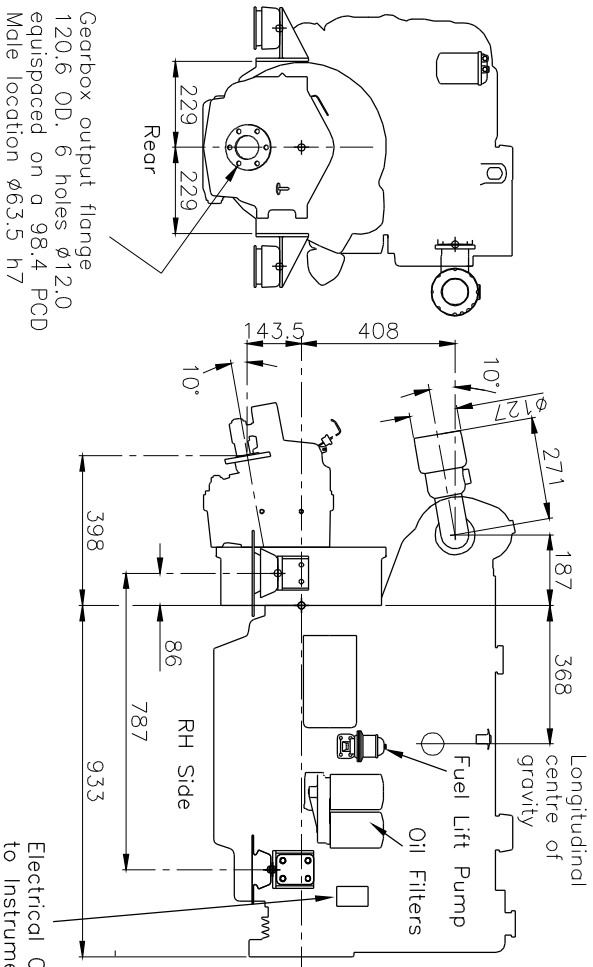
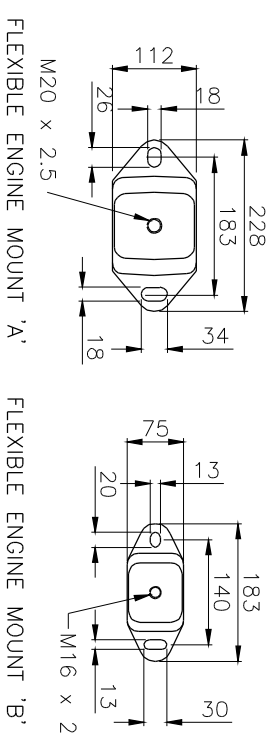
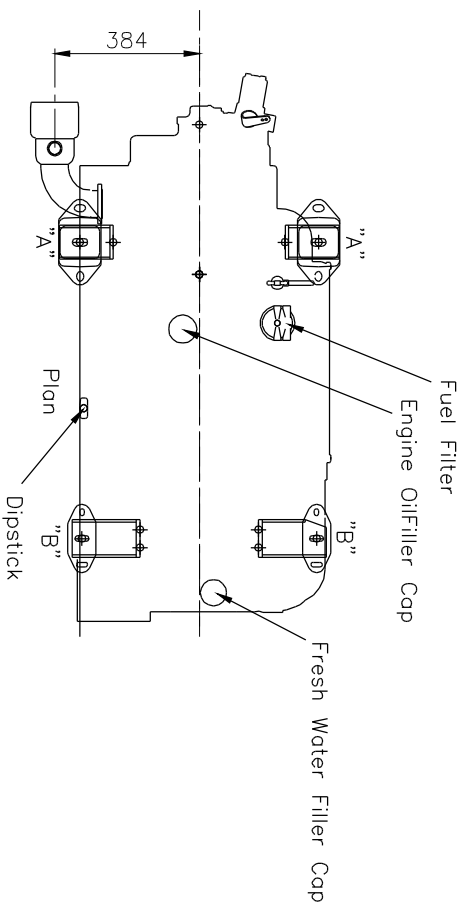

DOC 7092-6-00