

Perkins Sabre M92B Marine Diesel Engine
 shown with PRM 500D gearbox with reduction ratios
 up to and including 2.90:1 (550mm transverse mounting centres)

SABRE ENGINES LTD
 Wimborne, Dorset, England.
 Tel. +44(0)1202 893720
 Fax. +44(0)1202 851700
 E-mail. Post@Sabre-engines.co.uk
 www.Perkins-Sabre.com

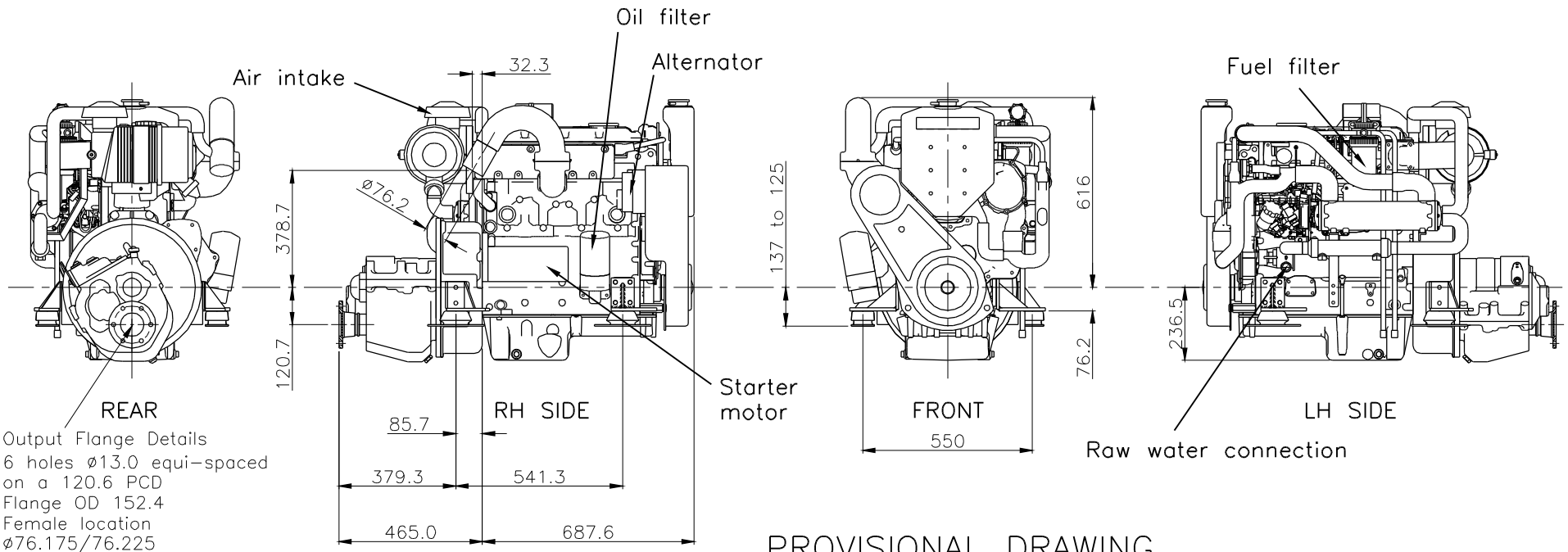
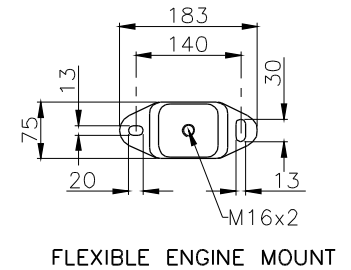
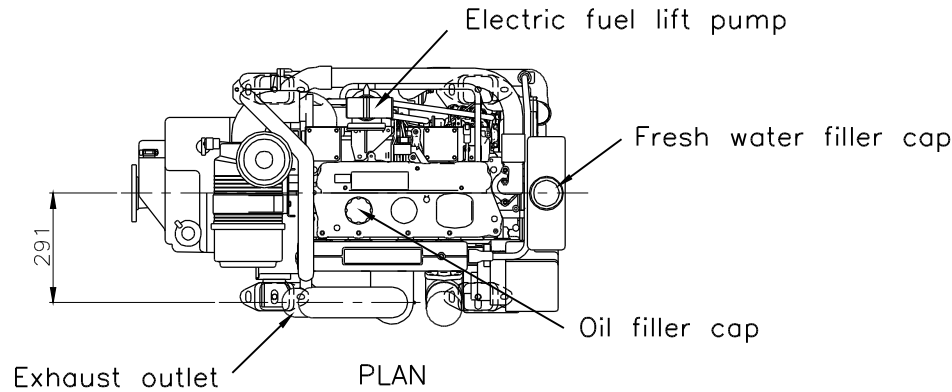

PROVISIONAL DRAWING

Doc No. 7353-1-04